



MOTOROLA

**MC1408
MC1508**

Specifications and Applications Information

EIGHT-BIT MULTIPLYING DIGITAL-TO-ANALOG CONVERTER

... designed for use where the output current is a linear product of an eight-bit digital word and an analog input voltage.

- Eight-Bit Accuracy Available in Both Temperature Ranges
Relative Accuracy: $\pm 0.19\%$ Error maximum (MC1408L8, MC1408P8, MC1508L8)
- Seven and Six-Bit Accuracy Available with MC1408 Designated by 7 or 6 Suffix after Package Suffix
- Fast Settling Time – 300 ns typical
- Noninverting Digital Inputs are MTTL and CMOS Compatible
- Output Voltage Swing – +0.4 V to -5.0 V
- High-Speed Multiplying Input
Slew Rate 4.0 mA/ μ s
- Standard Supply Voltages: +5.0 V and -5.0 V to -15 V

EIGHT-BIT MULTIPLYING DIGITAL-TO-ANALOG CONVERTER

SILICON MONOLITHIC INTEGRATED CIRCUIT

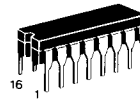

L SUFFIX
CERAMIC PACKAGE
CASE 620-02

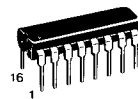

P SUFFIX
PLASTIC PACKAGE
CASE 648-05

D SUFFIX
PLASTIC PACKAGE
CASE 751B-01
SO-16*



*Surface Mount pin-out is different than standard package pin-out for this device. Please refer to Chapter 7 for details.

FIGURE 1 – D-to-A TRANSFER CHARACTERISTICS

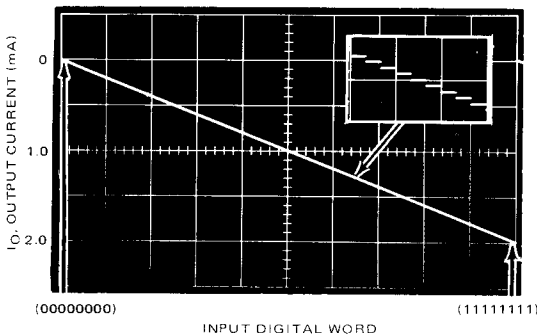
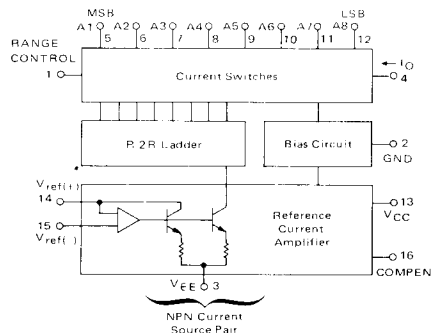

FIGURE 2 – BLOCK DIAGRAM



TYPICAL APPLICATIONS

- Tracking A-to-D Converters
- Successive Approximation A-to-D Converters
- 2 1/2 Digit Panel Meters and DVM's
- Waveform Synthesis
- Sample and Hold
- Peak Detector
- Programmable Gain and Attenuation
- CRT Character Generation
- Audio Digitizing and Decoding
- Programmable Power Supplies
- Analog-Digital Multiplication
- Digital-Digital Multiplication
- Analog-Digital Division
- Digital Addition and Subtraction
- Speech Compression and Expansion
- Stepping Motor Drive

MC1408, MC1508

MAXIMUM RATINGS (T_A = +25°C unless otherwise noted.)

Rating	Symbol	Value	Unit
Power Supply Voltage	V _{CC} V _{EE}	+5.5 -16.5	Vdc
Digital Input Voltage	V ₅ thru V ₁₂	0 to +5.5	Vdc
Applied Output Voltage	V _O	+0.5, -5.2	Vdc
Reference Current	I ₁₄	5.0	mA
Reference Amplifier Inputs	V ₁₄ , V ₁₅	V _{CC} , V _{EE}	Vdc
Operating Temperature Range	T _A	-55 to +125 0 to +75	°C
Storage Temperature Range	T _{stg}	-65 to +150	°C

ELECTRICAL CHARACTERISTICS (V_{CC} = +5.0 Vdc, V_{EE} = -15 Vdc, V_{ref}/R₁₄ = 2.0 mA, MC1508L8: T_A = -55°C to +125°C, MC1408L Series: T_A = 0 to +75°C unless otherwise noted. All digital inputs at high logic level.)

Characteristic	Figure	Symbol	Min	Typ	Max	Unit
Relative Accuracy (Error relative to full scale I _O) MC1508L8, MC1408L8, MC1408P8 MC1408P7, MC1408L7, See Note 1 MC1408P6, MC1408L6, See Note 1	4	E _r	—	—	±0.19 ±0.39 ±0.78	%
Settling Time to within ±1/2 LSB [includes t _{pLH}] (T _A = +25°C) See Note 2	5	t _S	—	300	—	ns
Propagation Delay Time T _A = +25°C	5	t _{pLH} , t _{pHL}	—	30	100	ns
Output Full Scale Current Drift		TCI _O	—	-20	—	PPM/°C
Digital Input Logic Levels (MSB) High Level, Logic "1" Low Level, Logic "0"	3	V _{IH} V _{IL}	2.0 —	— —	— 0.8	Vdc
Digital Input Current (MSB) High Level, V _{IH} = 5.0 V Low Level, V _{IL} = 0.8 V	3	I _{IH} I _{IL}	— —	0 -0.4	0.04 -0.8	mA
Reference Input Bias Current (Pin 15)	3	I ₁₅	—	-1.0	-5.0	μA
Output Current Range V _{EE} = -5.0 V V _{EE} = -15 V, T _A = 25°C	3	I _{OR}	0 0	2.0 2.0	2.1 4.2	mA
Output Current V _{ref} = 2.000 V, R ₁₄ = 1000 Ω	3	I _O	1.9	1.99	2.1	mA
Output Current (All bits low)	3	I _{O(min)}	—	0	4.0	μA
Output Voltage Compliance (E _r ≤ 0.19% at T _A = +25°C) Pin 1 grounded Pin 1 open, V _{EE} below -10 V	3	V _O	—	—	-0.55, +0.4 -5.0, +0.4	Vdc
Reference Current Slew Rate	6	SR I _{ref}	—	4.0	—	mA/μs
Output Current Power Supply Sensitivity		PSRR(-)	—	0.5	2.7	μA/V
Power Supply Current (All bits low)	3	I _{CC} I _{EE}	—	+13.5 -7.5	+22 -13	mA
Power Supply Voltage Range (T _A = +25°C)	3	V _{CCR} V _{EEER}	+4.5 -4.5	+5.0 -15	+5.5 -16.5	Vdc
Power Dissipation All bits low V _{EE} = -5.0 Vdc V _{EE} = -15 Vdc All bits high V _{EE} = -5.0 Vdc V _{EE} = -15 Vdc	3	P _D	—	105 190	170 305	mW

Note 1. All current switches are tested to guarantee at least 50% of rated output current.

Note 2. All bits switched.

TEST CIRCUITS

FIGURE 3 – NOTATION DEFINITIONS TEST CIRCUIT

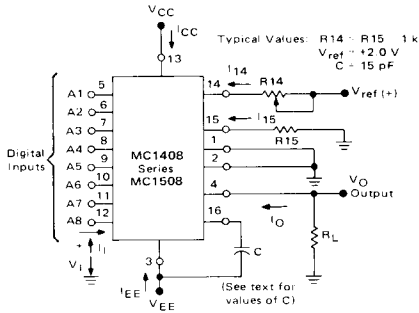

V_I and I_I apply to inputs A1 thru A8

The resistor tied to pin 15 is to temperature compensate the bias current and may not be necessary for all applications.

$$I_O = K \left\{ \frac{A_1}{2} + \frac{A_2}{4} + \frac{A_3}{8} + \frac{A_4}{16} + \frac{A_5}{32} + \frac{A_6}{64} + \frac{A_7}{128} + \frac{A_8}{256} \right\}$$

where $K \cong \frac{V_{ref}}{R_{14}}$

and $A_N = "1"$ if A_N is at high level
 $A_N = "0"$ if A_N is at low level

FIGURE 4 – RELATIVE ACCURACY TEST CIRCUIT

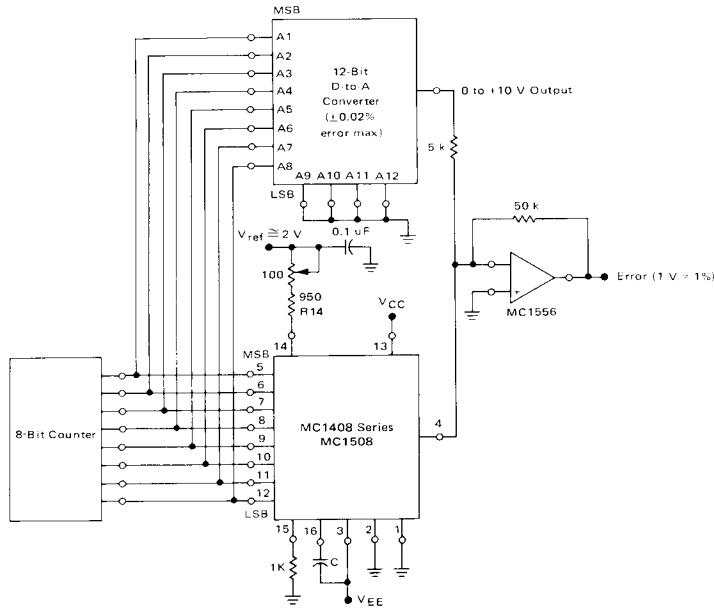
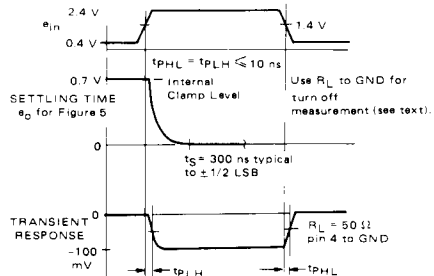
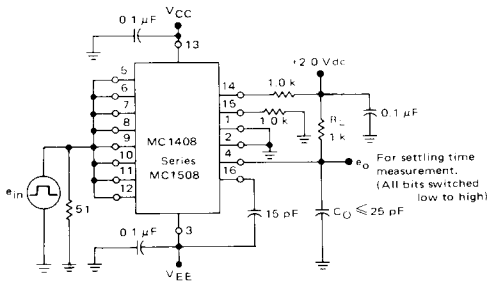

FIGURE 5 – TRANSIENT RESPONSE and SETTLING TIME



TEST CIRCUITS (continued)

FIGURE 6 – REFERENCE CURRENT SLEW RATE MEASUREMENT

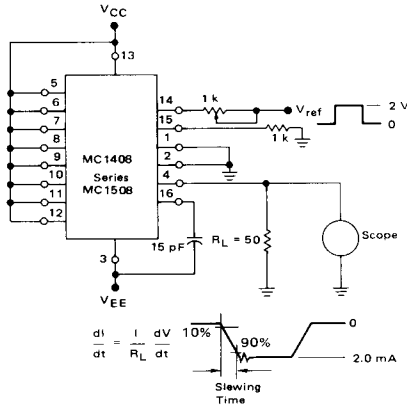

FIGURE 7 – POSITIVE V_{ref}

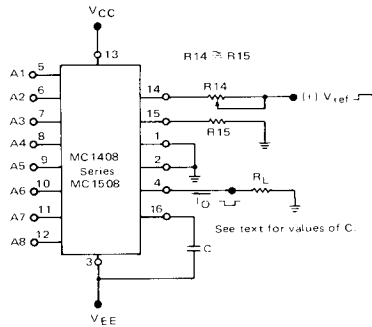

FIGURE 8 – NEGATIVE V_{ref}

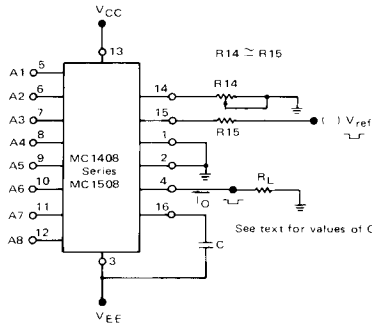
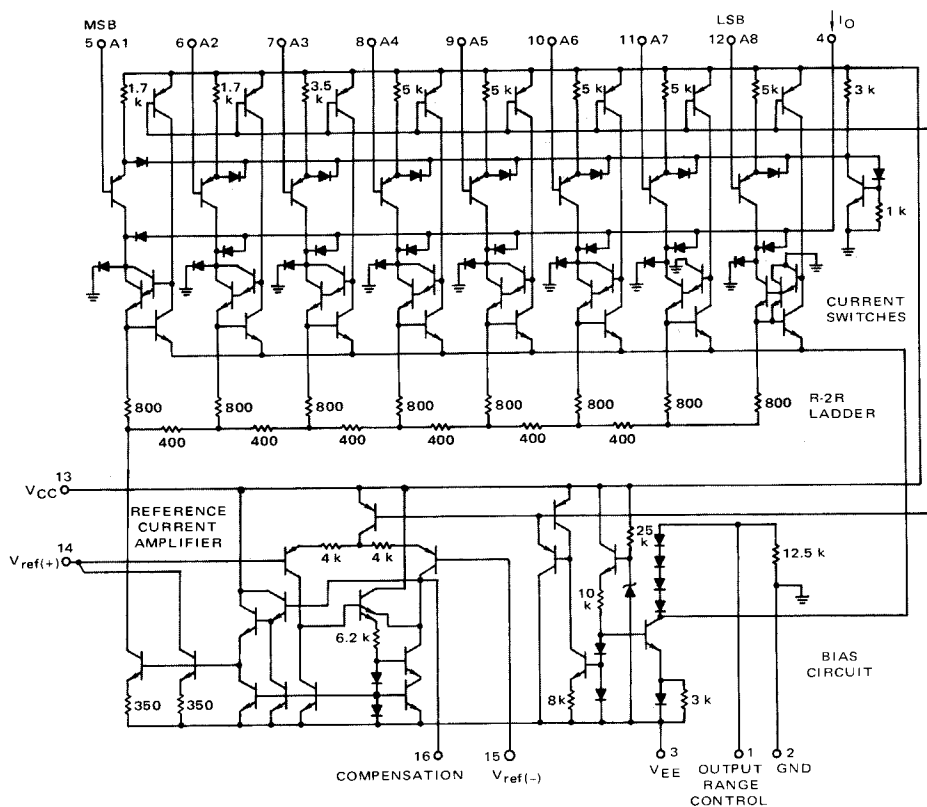

FIGURE 9 – MC1408, MC1508 SERIES EQUIVALENT
CIRCUIT SCHEMATIC
DIGITAL INPUTS



CIRCUIT DESCRIPTION

The MC1408 consists of a reference current amplifier, an R-2R ladder, and eight high-speed current switches. For many applications, only a reference resistor and reference voltage need be added.

The switches are noninverting in operation, therefore a high state on the input turns on the specified output current component. The switch uses current steering for high speed, and a termination amplifier consisting of an active load gain stage with unity gain feedback. The termination amplifier holds the parasitic capacitance of the ladder at a constant voltage during switching, and provides

a low impedance termination of equal voltage for all legs of the ladder.

The R-2R ladder divides the reference amplifier current into binary-related components, which are fed to the switches. Note that there is always a remainder current which is equal to the least significant bit. This current is shunted to ground, and the maximum output current is 255/256 of the reference amplifier current, or 1.992 mA for a 2.0 mA reference amplifier current if the NPN current source pair is perfectly matched.

GENERAL INFORMATION

Reference Amplifier Drive and Compensation

The reference amplifier provides a voltage at pin 14 for converting the reference voltage to a current, and a turn-around circuit or current mirror for feeding the ladder. The reference amplifier input current, I14, must always flow into pin 14 regardless of the setup method or reference voltage polarity.

Connections for a positive reference voltage are shown in Figure 7. The reference voltage source supplies the full current I14. For bipolar reference signals, as in the multiplying mode, R15 can be tied to a negative voltage corresponding to the minimum input level. It is possible to eliminate R15 with only a small sacrifice in accuracy and temperature drift. Another method for bipolar inputs is shown in Figure 25.

The compensation capacitor value must be increased with increases in R14 to maintain proper phase margin; for R14 values of 1.0, 2.5 and 5.0 kilohms, minimum capacitor values are 15, 37, and 75 pF. The capacitor should be tied to V_{EE} as this increases negative supply rejection.

A negative reference voltage may be used if R14 is grounded and the reference voltage is applied to R15 as shown in Figure 8. A high input impedance is the main advantage of this method. Compensation involves a capacitor to V_{EE} on pin 16, using the values of the previous paragraph. The negative reference voltage must be at least 3.0-volts above the V_{EE} supply. Bipolar input signals may be handled by connecting R14 to a positive reference voltage equal to the peak positive input level at pin 15.

When a dc reference voltage is used, capacitive bypass to ground is recommended. The 5.0-V logic supply is not recommended as a reference voltage. If a well regulated 5.0-V supply which drives logic is to be used as the reference, R14 should be decoupled by connecting it to +5.0 V through another resistor and bypassing the junction of the two resistors with 0.1 μ F to ground. For reference voltages greater than 5.0 V, a clamp diode is recommended between pin 14 and ground.

If pin 14 is driven by a high impedance such as a transistor current source, none of the above compensation methods apply and the amplifier must be heavily compensated, decreasing the overall bandwidth.

Output Voltage Range

The voltage on pin 4 is restricted to a range of -0.55 to +0.4 volts at +25°C, due to the current switching methods employed in the MC1408. When a current switch is turned "off", the positive voltage on the output terminal can turn "on" the output diode and increase the output current level. When a current switch is turned "on", the negative output voltage range is restricted. The base of the termination circuit Darlington transistor is one diode voltage below ground when pin 1 is grounded, so a negative voltage below the specified safe level will drive the low current device of the Darlington into saturation, decreasing the output current level.

The negative output voltage compliance of the MC1408 may be extended to -5.0 V volts by opening the circuit at pin 1. The negative supply voltage must be more negative than -10 volts. Using a full scale current of 1.992 mA and load resistor of 2.5 kilohms between pin 4 and ground will yield a voltage output of 256 levels between 0 and -4.980 volts. Floating pin 1 does not affect the converter speed or power dissipation. However, the value of the load resistor determines the switching time due to increased voltage swing. Values of R_L up to 500 ohms do not significantly affect performance, but a 2.5-kilohm load increases "worst case" settling time to 1.2 μ s (when all bits are switched on).

Refer to the subsequent text section on Settling Time for more details on output loading.

If a power supply value between -5.0 V and -10 V is desired, a voltage of between 0 and -5.0 V may be applied to pin 1. The value of this voltage will be the maximum allowable negative output swing.

Output Current Range

The output current maximum rating of 4.2 mA may be used only for negative supply voltages typically more negative than -8.0 volts, due to the increased voltage drop across the 350-ohm resistors in the reference current amplifier.

Accuracy

Absolute accuracy is the measure of each output current level with respect to its intended value, and is dependent upon relative accuracy and full scale current drift. Relative accuracy is the measure of each output current level as a fraction of the full scale current. The relative accuracy of the MC1408 is essentially constant with temperature due to the excellent temperature tracking of the monolithic resistor ladder. The reference current may drift with temperature, causing a change in the absolute accuracy of output current. However, the MC1408 has a very low full scale current drift with temperature.

The MC1408/MC1508 Series is guaranteed accurate to within $\pm 1/2$ LSB at +25°C at a full scale output current of 1.992 mA. This corresponds to a reference amplifier output current drive to the ladder network of 2.0 mA, with the loss of one LSB = 8.0 μ A which is the ladder remainder shunted to ground. The input current to pin 14 has a guaranteed value of between 1.9 and 2.1 mA, allowing some mismatch in the NPN current source pair. The accuracy test circuit is shown in Figure 4. The 12-bit converter is calibrated for a full scale output current of 1.992 mA. This is an optional step since the MC1408 accuracy is essentially the same between 1.5 and 2.5 mA. Then the MC1408 circuits' full scale current is trimmed to the same value with R14 so that a zero value appears at the error amplifier output. The counter is activated and the error band may be displayed on an oscilloscope, detected by comparators, or stored in a peak detector.

Two 8-bit D-to-A converters may not be used to construct a 16-bit accurate D-to-A converter. 16-bit accuracy implies a total error of $\pm 1/2$ of one part in 65,536, or $\pm 0.00076\%$, which is much more accurate than the $\pm 0.19\%$ specification provided by the MC1408x8.

Multiplying Accuracy

The MC1408 may be used in the multiplying mode with eight-bit accuracy when the reference current is varied over a range of 256:1. The major source of error is the bias current of the termination amplifier. Under "worst case" conditions, these eight amplifiers can contribute a total of 1.6 μ A extra current at the output terminal. If the reference current in the multiplying mode ranges from 16 μ A to 4.0 mA, the 1.6 μ A contributes an error of 0.1 LSB. This is well within eight-bit accuracy referenced to 4.0 mA.

A monotonic converter is one which supplies an increase in current for each increment in the binary word. Typically, the MC1408 is monotonic for all values of reference current above 0.5 mA. The recommended range for operation with a dc reference current is 0.5 to 4.0 mA.

GENERAL INFORMATION (Continued)

Settling Time

The "worst case" switching condition occurs when all bits are switched "on", which corresponds to a low-to-high transition for all bits. This time is typically 300 ns for settling to within $\pm 1/2$ LSB, for 8-bit accuracy, and 200 ns to 1/2 LSB for 7 and 6-bit accuracy. The turn off is typically under 100 ns. These times apply when $R_L \leq 500$ ohms and $C_O \leq 25$ pF.

The slowest single switch is the least significant bit, which turns "on" and settles in 250 ns and turns "off" in 80 ns. In applications where the D-to-A converter functions in a positive-going ramp mode, the "worst case" switching condition does not occur, and a settling time of less than 300 ns may be realized. Bit A7 turns "on" in 200 ns and "off" in 80 ns, while bit A6 turns "on" in 150 ns and "off" in 80 ns.

The test circuit of Figure 5 requires a smaller voltage swing for the current switches due to internal voltage clamping in the MC-1408. A 1.0-kilohm load resistor from pin 4 to ground gives a typical settling time of 400 ns. Thus, it is voltage swing and not the output RC time constant that determines settling time for most applications.

Extra care must be taken in board layout since this is usually the dominant factor in satisfactory test results when measuring settling time. Short leads, 100 μ F supply bypassing for low frequencies, and minimum scope lead length are all mandatory.

TYPICAL CHARACTERISTICS

($V_{CC} = +5.0$ V, $V_{EE} = -15$ V, $T_A = +25^\circ\text{C}$ unless otherwise noted.)

FIGURE 10 – LOGIC INPUT CURRENT versus INPUT VOLTAGE

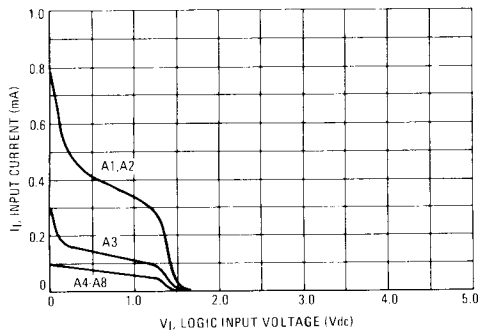

FIGURE 11 – TRANSFER CHARACTERISTIC versus TEMPERATURE (A5 thru A8 thresholds lie within range for A1 thru A4)

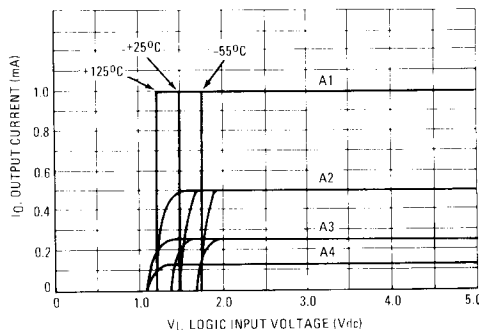

FIGURE 12 – OUTPUT CURRENT versus OUTPUT VOLTAGE (See text for pin 1 restrictions)

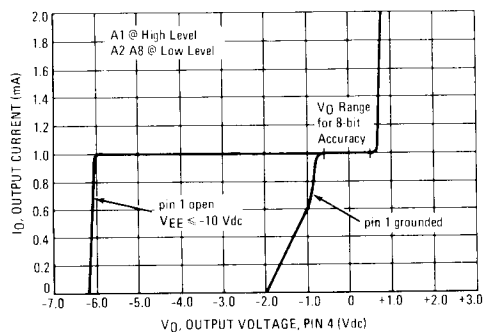
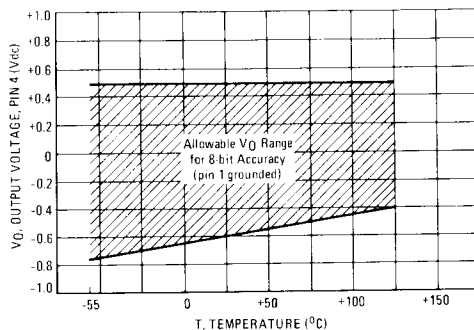

FIGURE 13 – OUTPUT VOLTAGE versus TEMPERATURE (Negative range with pin 1 open is -5.0 Vdc over full temperature range)



TYPICAL CHARACTERISTICS (continued)

($V_{CC} = +5.0\text{ V}$, $V_{EE} = -15\text{ V}$, $T_A = +25^\circ\text{C}$ unless otherwise noted.)

FIGURE 14 — REFERENCE INPUT FREQUENCY RESPONSE

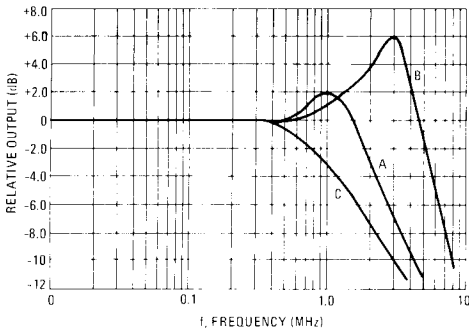

Unless otherwise specified:

- R14 = R15 = 1.0 k Ω
- C = 15 pF, pin 16 to V_{EE}
- R_L = 50 Ω , pin 4 to GND

- Curve A: Large Signal Bandwidth
Method of Figure 7
 $V_{ref} = 2.0\text{ V}$ (p-p) offset 1.0 V above GND
- Curve B: Small Signal Bandwidth
Method of Figure 7, R_L = 250 Ω
 $V_{ref} = 50\text{ mV}$ (p-p) offset 200 mV above GND
- Curve C: Large and Small Signal Bandwidth
Method of Figure 25 (no op-amp), R_L = 50 Ω
R_S = 50 Ω
 $V_{ref} = 2.0\text{ V}$
 $V_S = 100\text{ mV}$ (p-p) centered at 0 V

FIGURE 15 — TYPICAL POWER SUPPLY CURRENT versus TEMPERATURE (all bits low)

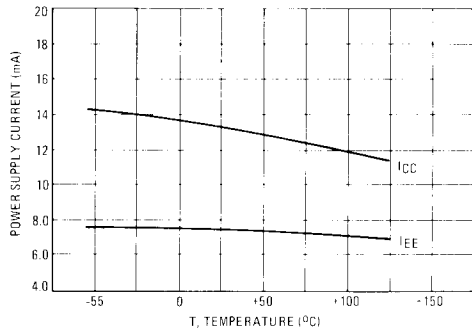
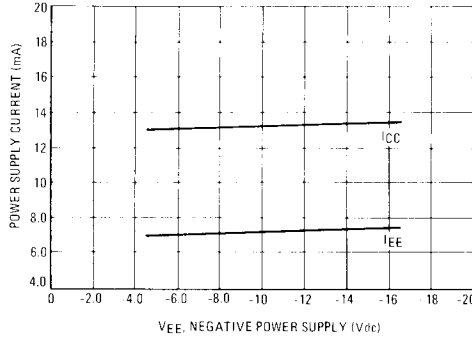
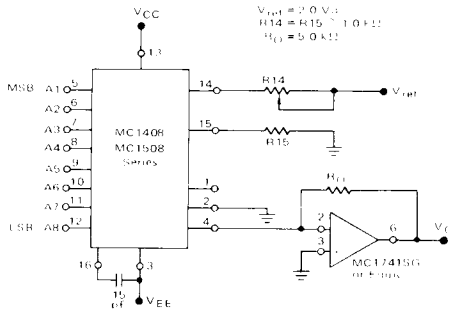

FIGURE 16 — TYPICAL POWER SUPPLY CURRENT versus V_{EE} (all bits low)



APPLICATIONS INFORMATION

FIGURE 17 — OUTPUT CURRENT TO VOLTAGE CONVERSION



Theoretical V_O

$$V_O = \frac{V_{ref}}{R_{14}} \cdot R_{(f)} \left[\frac{A_1}{2} + \frac{A_2}{4} + \frac{A_3}{8} + \frac{A_4}{16} + \frac{A_5}{32} + \frac{A_6}{64} + \frac{A_7}{128} + \frac{A_8}{256} \right]$$

Adjust V_{ref} , R14 or $R_{(f)}$ so that V_O with all digital inputs at high level is equal to 9.961 volts

$$V_O = \frac{2\text{ V}}{1\text{ k}} \cdot 5\text{ k} \left[\frac{1}{2} + \frac{1}{4} + \frac{1}{8} + \frac{1}{16} + \frac{1}{32} + \frac{1}{64} + \frac{1}{128} + \frac{1}{256} \right]$$

$$= 10\text{ V} \left[\frac{255}{256} \right] = 9.961\text{ V}$$

APPLICATIONS INFORMATION (continued)

Voltage outputs of a larger magnitude are obtainable with this circuit which uses an external operational amplifier as a current to voltage converter. This configuration automatically keeps the output of the MC1408 at ground potential and the operational amplifier can generate a positive voltage limited only by its positive supply voltage. Frequency response and settling time are primarily determined by the characteristics of the operational amplifier. In addition, the operational amplifier must be compensated for unity gain, and in some cases overcompensation may be desirable.

Note that this configuration results in a positive output voltage only, the magnitude of which is dependent on the digital input.

The following circuit shows how the MLM301AG can be used in a feedforward mode resulting in a full scale settling time on the order of 2.0 μ s.

FIGURE 18

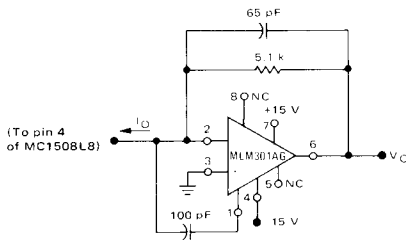

An alternative method is to use the MC1539G and input compensation. Response of this circuit is also on the order of 2.0 μ s. See Motorola Application Note AN-459 for more details on this concept.

FIGURE 19

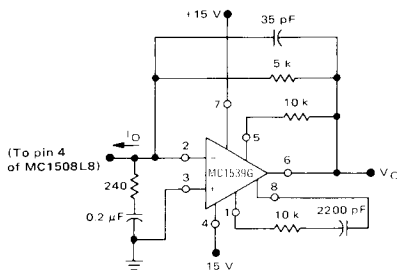

The positive voltage range may be extended by cascading the output with a high beta common base transistor, Q1, as shown.

FIGURE 20 – EXTENDING POSITIVE VOLTAGE RANGE

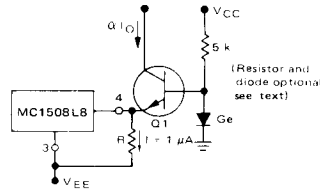

The output voltage range for this circuit is 0 volts to BV_{CBO} of the transistor. If pin 1 is left open, the transistor base may be grounded, eliminating both the resistor and the diode. Variations in beta must be considered for wide temperature range applications. An inverted output waveform may be obtained by using a load resistor from a positive reference voltage to the collector of the transistor. Also, high-speed operation is possible with a large output voltage swing, because pin 4 is held at a constant voltage. The resistor (R) to V_{EE} maintains the transistor emitter voltage when all bits are "off" and insures fast turn-on of the least significant bit.

Combined Output Amplifier and Voltage Reference

For many of its applications the MC1408 requires a reference voltage and an operational amplifier. Normally the operational amplifier is used as a current to voltage converter and its output need only go positive. With the popular MC1723G voltage regulator both of these functions are provided in a single package with the added bonus of up to 150 mA of output current. See Figure 21. The MC1723G uses both a positive and negative power supply. The reference voltage of the MC1723G is then developed with respect to the negative voltage and appears as a common-mode signal to the reference amplifier in the D-to-A converter. This allows use of its output amplifier as a classic current-to-voltage converter with the non-inverting input grounded.

Since ± 15 V and +5.0 V are normally available in a combination digital-to-analog system, only the -5.0 V need be developed. A resistor divider is sufficiently accurate since the allowable range on pin 5 is from -2.0 to -8.0 volts. The 5.0 kilohm pull-down resistor on the amplifier output is necessary for fast negative transitions.

Full scale output may be increased to as much as 32 volts by increasing R_O and raising the +15 V supply voltage to 35 V maximum. The resistor divider should be altered to comply with the maximum limit of 40 volts across the MC1723G. C_O may be decreased to maintain the same $R_O C_O$ product if maximum speed is desired.

APPLICATIONS INFORMATION (continued)

Programmable Power Supply

The circuit of Figure 21 can be used as a digitally programmed power supply by the addition of thumbwheel switches and a BCD-to-binary converter. The output voltage can be scaled in several ways, including 0 to +25.5 volts in 0.1-volt increments, ±0.05 volt; or 0 to 5.1 volts in 20 mV increments, ±10 mV.

FIGURE 21 — COMBINED OUTPUT AMPLIFIER and VOLTAGE REFERENCE CIRCUIT

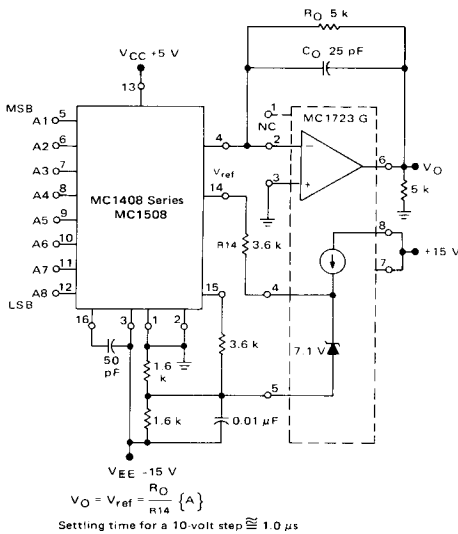

$$V_O = V_{ref} \frac{R_O}{R_{14}} \{A\}$$

Setting time for a 10-volt step $\approx 1.0 \mu s$

Bipolar or Negative Output Voltage

The circuit of Figure 22 is a variation from the standard voltage output circuit and will produce bipolar output signals. A positive current may be sourced into the summing node to offset the output voltage in the negative direction. For example, if approximately 1.0 mA is used a bipolar output signal results which may be described as a 8-bit "1's" complement offset binary. V_{ref} may be used as this auxiliary reference. Note that R_O has been doubled to 10 kilohms because of the anticipated 20 V(p-p) output range.

FIGURE 22 — BIPOLAR OR NEGATIVE OUTPUT VOLTAGE CIRCUIT

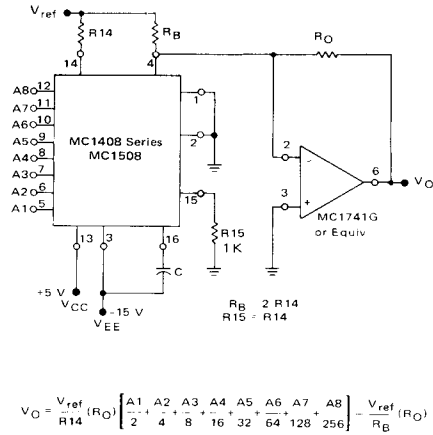

$$V_O = \frac{V_{ref}}{R_{14}} (R_O) \left[\frac{A_1}{2} + \frac{A_2}{4} + \frac{A_3}{8} + \frac{A_4}{16} + \frac{A_5}{32} + \frac{A_6}{64} + \frac{A_7}{128} + \frac{A_8}{256} \right] - \frac{V_{ref}}{R_B} (R_O)$$

FIGURE 23 — BIPOLAR OR INVERTED NEGATIVE OUTPUT VOLTAGE CIRCUIT

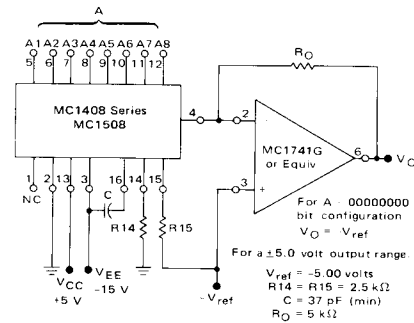

For A 00000000 bit configuration $V_O = V_{ref}$
 For a ±5.0 volt output range:
 $V_{ref} = -5.00$ volts
 $R_{14} = R_{15} = 2.5$ kΩ
 $C = 37$ pF (min)
 $R_O = 5$ kΩ

Decrease R_O to 2.5 kΩ for a 0 to -5.0-volt output range. This application provides somewhat lower speed, as previously discussed in the Output Voltage Range section of the General Information.

APPLICATIONS INFORMATION (continued)

Polarity Switching Circuit, 8-Bit Magnitude Plus Sign D-to-A Converter

Bipolar outputs may also be obtained by using a polarity switching circuit. The circuit of Figure 24 gives 8-bit magnitude plus a sign bit. In this configuration the operational amplifier is switched between a gain of +1.0 and -1.0. Although another operational amplifier is required, no more space is taken when a dual operational amplifier such as the MC1558G is used. The transistor should be selected for a very low saturation voltage and resistance.

FIGURE 24 — POLARITY SWITCHING CIRCUIT (8-Bit Magnitude Plus Sign D-to-A Converter)

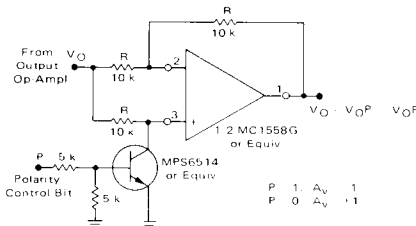

Programmable Gain Amplifier or Digital Attenuator

When used in the multiplying mode the MC1408 can be applied as a digital attenuator. See Figure 25. One advantage of this technique is that if $R_S = 50$ ohms, no compensation capacitor is needed. The small and large signal bandwidths are now identical and are shown in Figure 14.

The best frequency response is obtained by not allowing I_{14} to reach zero. However, the high impedance node, pin 16, is clamped to prevent saturation and insure fast recovery when the current through R_{14} goes to zero. R_S can be set for a ± 1.0 mA variation in relation to I_{14} . I_{14} can never be negative.

The output current is always unipolar. The quiescent dc output current level changes with the digital word which makes ac coupling necessary.

FIGURE 25 — PROGRAMMABLE GAIN AMPLIFIER OR DIGITAL ATTENUATOR CIRCUIT

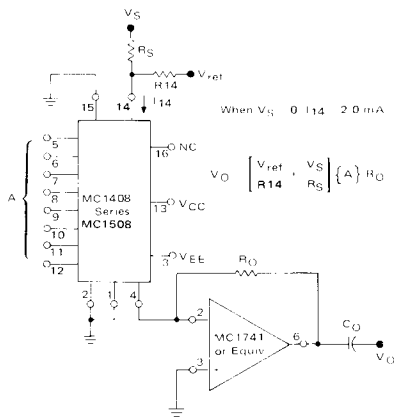

Panel Meter Readout

The MC1408 can be used to read out the status of 8CD or binary registers or counters in a digital control system. The current output can be used to drive directly an analog panel meter. External meter shunts may be necessary if a meter of less than 2.0 mA full scale is used. Full scale calibration can be done by adjusting R_{14} or V_{ref} .

FIGURE 26 — PANEL METER READOUT CIRCUIT

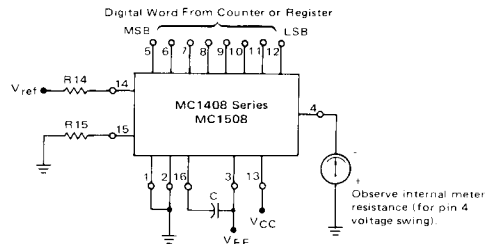

FIGURE 27 — DC COUPLED DIGITAL ATTENUATOR and DIGITAL SUBTRACTION

